



JETSPRAY COMPACT

Compressed air and
water spray humidifier



Humidification, Dehumidification
and Evaporative Cooling

 **condair**

Easy to install, direct room humidifier offering up to 30 kg/h of humidification

Fully assembled, easy-to-install

Supplied with two nozzles, as standard, the unit is preassembled and ready for use.

Humidistat with display



Allows the required room humidity to be set and monitored, which in turn controls the output of the humidifier.

Electrical connection

Air connection

Compressed air ensures rapid evaporation of the aerosols, without the risk of drips.

Water supply



Optional PureFlo antibacterial filter, to combat microbial growth, together with a 5 micron particle filter.

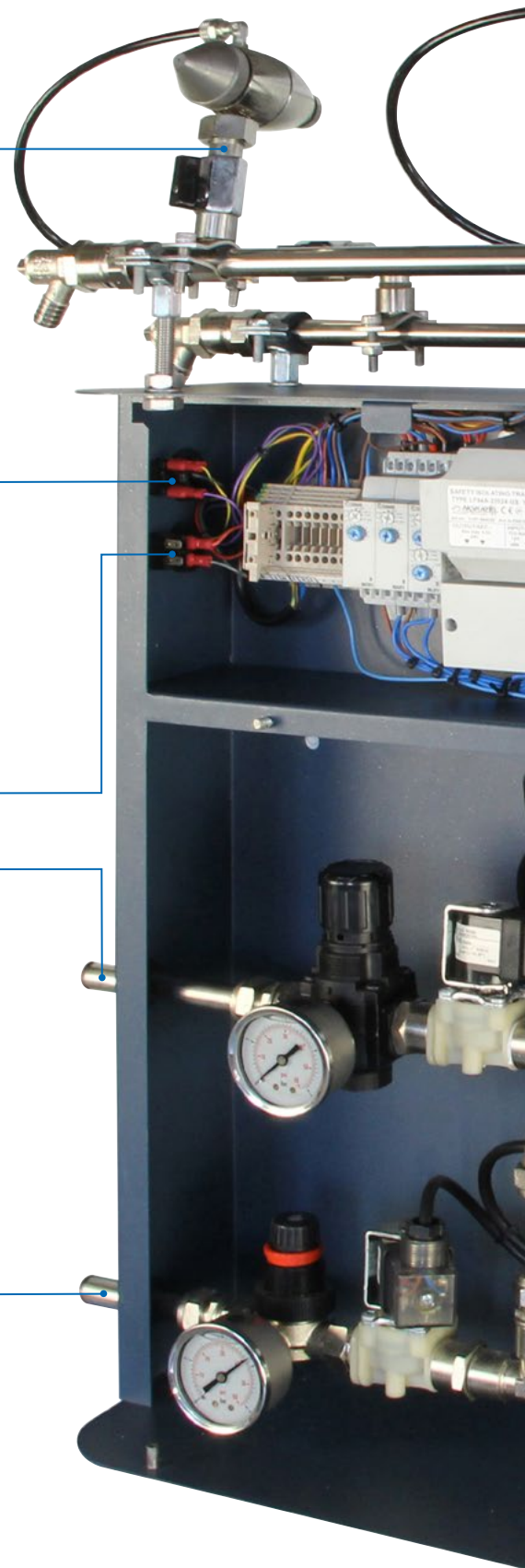

JETSPRAY COMPACT

Compressed air and water spray humidifier

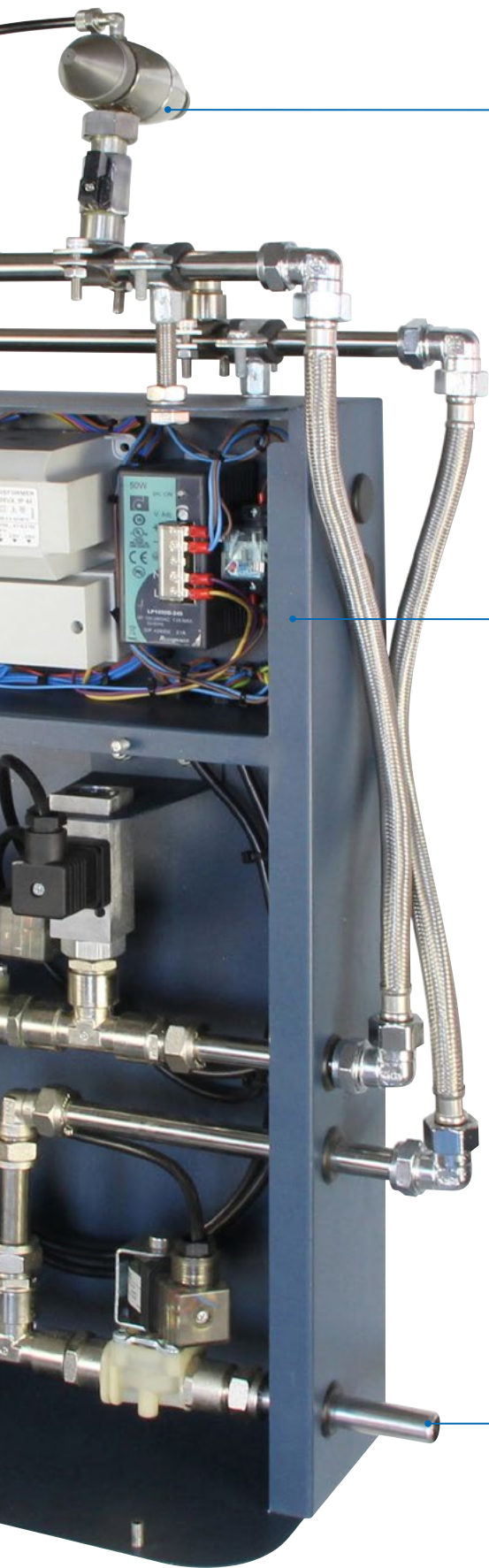

Self-cleaning nozzles



An internal pin prevents blockages, resulting in robust operation in industrial environments. The nozzles come in a variety of outputs and are directionally adjustable, horizontally and vertically.

Cabinet

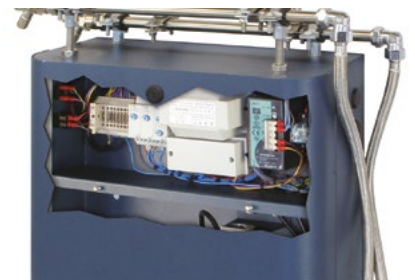

IP54 rated, as standard, with all internals easily accessible for operation and maintenance. The electrical components are mounted in a separate compartment located above the water and air pipes.

Hygiene

Advanced hygiene features include start-up water line purge, daily flush and full drain down of the water lines when not in use.

Drain

The JetSpray Compact is an easy-to-install, direct room humidifier for areas that need up to 30 kg/h. As it is preassembled, it does not require installation of additional nozzles or associated pipework.

Operation with compressed air gives very reliable operation, in dusty industrial environments, without any risk of drips. This makes the JetSpray Compact ideal for use in sectors such as textile, tea, food, tobacco and printing.

As well as reliable operation, advanced hygiene features ensure the humidifier provides safe operation. Water treatment and flush and drain cycles minimise the risk of microbial growth in the system.

Typical system overview

- 1 Cabinet (IP54 rated)
- 2 Water supply with optional anti-bacterial filter set
- 3 Compressed air in
- 4 Drain
- 5 Condair CHR humidistat with display (optional)
- 6 Nozzles (x2)

Other options

- Room humidistat
- Booster water pump and tank
- RO water filter

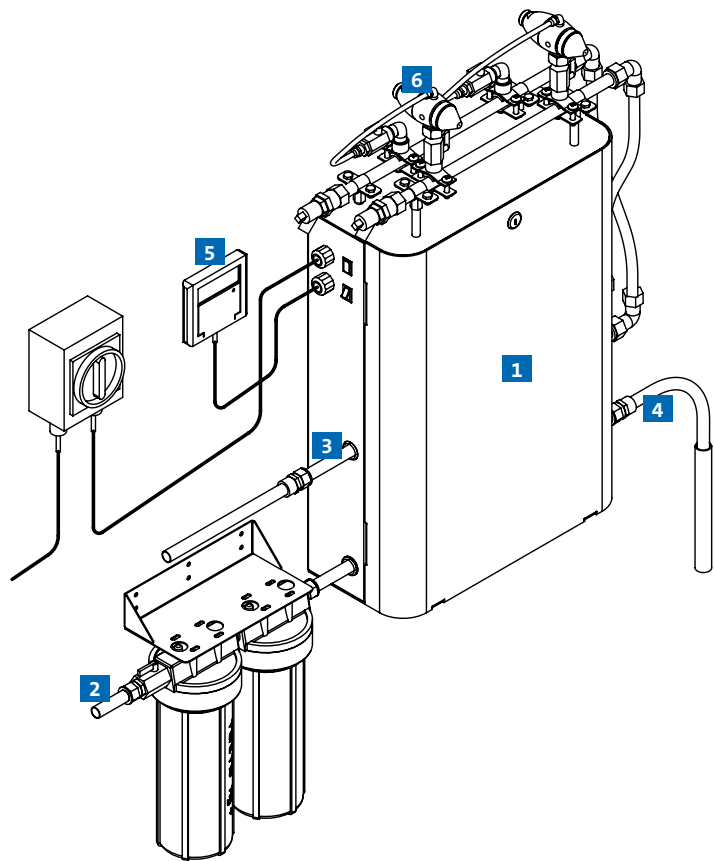

Technical data

	JS60C-5	JS60C-7	JS60C-9	JS60C-11	JS60C-13	JS60C-18	JS60C-24	JS60C-30
Output (kg/h)	5	7	9	11	13	18	24	30
Humidity control	±4 % RH							
Control	On/Off							
Dimensions	W 380 mm x H 740 mm x D 167 mm							
Weight	18 kg							
Power supply	120VAC/230 VAC 50/60Hz							
Power consumption	0.17 - 0.21 kW				0.7 - 0.87 A			

Distribution:



Condair Systems GmbH
 Nordportbogen 5, 22848 Norderstedt
 Phone: +49 40 853277-0
 info@condair-systems.eu, www.condair-systems.eu

Condair China Ltd.
 Section C, Building 3,
 OPTO Mechatronics Industrial Park,
 Beijing 101111, China
 Phone: +86 (10) 8150 3008
 service.cn@condair.com - www.condair.com.cn

